

Silicon Power Rectifier S/R25 Series

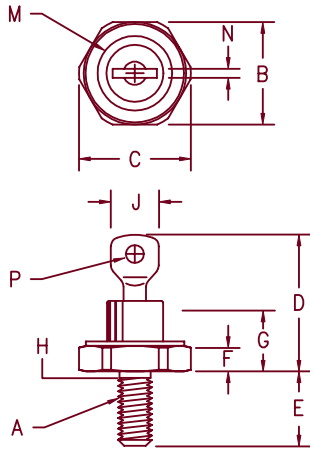

Notes:

1. 10-32 UNF3A
2. Full threads within 2 1/2 threads
3. Standard Polarity: Stud is Cathode
Reverse Polarity: Stud is Anode

Dim.	Inches		Millimeter		Notes
	Minimum	Maximum	Minimum	Maximum	
A	---	---	---	---	1
B	.424	.437	10.77	11.10	
C	---	.505	---	12.82	
D	.600	.800	15.24	20.32	
E	.422	.453	10.72	11.50	
F	.075	.175	1.91	4.44	
G	---	.405	---	10.29	
H	.163	.189	4.15	4.80	2
J	---	.310	---	7.87	
M	---	.350	---	8.89	Dia
N	.020	.065	.510	1.65	
P	.070	.100	1.78	2.54	Dia

Microsemi Catalog Number	Peak Reverse Voltage
1N1199C	50V
1N1200C	100V
1N1201C	150V
*S2520 1N1202C	200V
*S2540 1N1203C	300V
1N1204C	400V
1N1205C	500V
*S2560 1N1206C	600V
*S2580	800V
*S25100	1000V
*S25120	1200V
*S25140	1400V
*S25160	1600V
1N3615	50V
1N3616	100V
1N3617	150V
1N3618	200V
1N3619	300V
1N3620	400V
1N3621	500V
1N3622	600V
1N3623	800V
1N3624	1000V

*Change S to R in part number for Reverse Polarity
For 1N types, add R suffix for Reverse Polarity

DO203AA (D04)

- Glass Passivated Die
- Low Forward Voltage
- 400A Surge Rating
- Glass to metal seal construction
- V_{RRM} to 1600V
- Excellent reliability

Electrical Characteristics

Average forward current	IF(AV) 25 Amps	$T_C = 134^\circ\text{C}$, half sine wave, $R_{\theta JC} = 2.0^\circ\text{C/W}$
Maximum surge current	IFSM 400 Amps	8.3ms, half sine, $T_J = 200^\circ\text{C}$
Max $I^2 t$ for fusing	$I^2 t$ 660 A ² s	
Max peak forward voltage	V _{FM} 1.1 Volts	IFM = 30A: $T_J = 25^\circ\text{C}$ *
Max peak reverse current	IRM 10 μA	$V_{RRM, T_J} = 25^\circ\text{C}$
Max peak reverse current	IRM 1.0 mA	$V_{RRM, T_J} = 150^\circ\text{C}$
Max Recommended Operating Frequency	10kHz	

*Pulse test: Pulse width 300 μsec . Duty cycle 2%

Thermal and Mechanical Characteristics

Storage temperature range	T _{STG}	-65°C to 200°C
Operating junction temp range	T _J	-65°C to 200°C
Maximum thermal resistance	R _{θJC}	2.0°C/W Junction to Case
Mounting torque		25-30 inch pounds
Weight		.16 ounces (5.0 grams) typical

11-15-00 Rev. 2

S/R25

Figure 1
Maximum Forward Characteristics

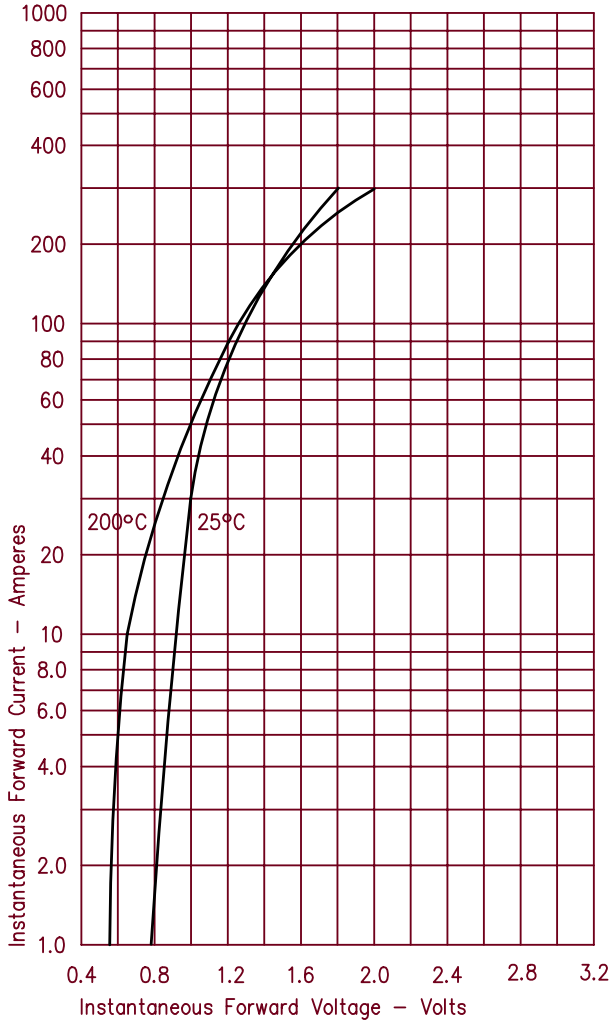

Figure 3
Forward Current Derating

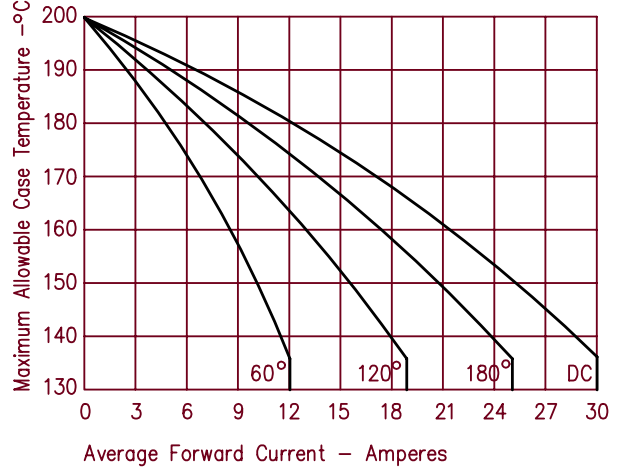

Figure 4
Transient Thermal Impedance

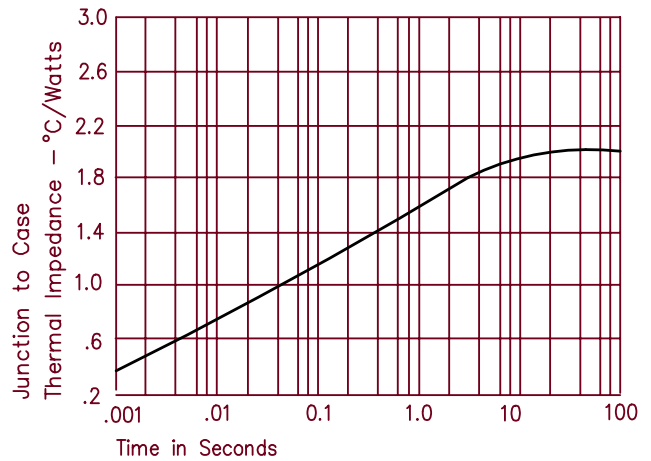

Figure 2
Typical Reverse Characteristics

