

100313

Low Power Quad Driver

General Description

The 100313 is a monolithic quad driver with two OR and two NOR outputs and common enable. The common input is buffered to minimize input loading. If the D inputs are not used the Enable can be used to drive sixteen 50Ω lines. All inputs have 50 kΩ pull-down resistors and all outputs are buffered.

Features

- 50% power reduction of the 100113
- 2000V ESD protection
- Pin/function compatible with 100113 and 100112
- Voltage compensated operating range = -4.2V to -5.7V
- Standard Microcircuit Drawing (SMD) 5962-9673201

Logic Symbol

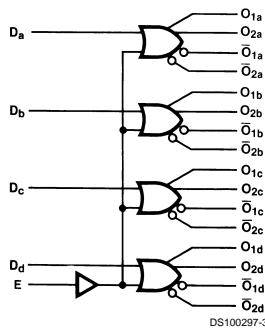

Pin Names	Description
D _a -D _d	Data Inputs
E	Enable Input
O _{na} -O _{nd}	Data Outputs
\bar{O}_{na} - \bar{O}_{nd}	Complementary Data Outputs

Connection Diagrams

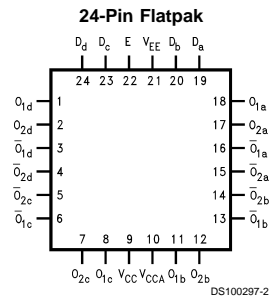
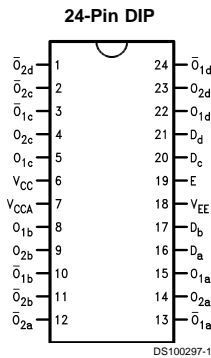

Absolute Maximum Ratings (Note 1)

If Military/Aerospace specified devices are required, please contact the National Semiconductor Sales Office/Distributors for availability and specifications.

Storage Temperature (T_{STG})	-65°C to +150°C
Maximum Junction Temperature (T_J)	
Ceramic	+175°C
V_{EE} Pin Potential to Ground Pin	-7.0V to +0.5V
Input Voltage (DC)	V_{EE} to +0.5V
Output Current (DC Output HIGH)	-50 mA
ESD (Note 2)	≥2000V

Military Version DC Electrical Characteristics

$V_{EE} = -4.2V$ to $-5.7V$, $V_{CC} = V_{CCA} = GND$, $T_C = -55^\circ C$ to $+125^\circ C$

Symbol	Parameter	Min	Max	Units	T_C	Conditions	Notes	
V_{OH}	Output HIGH Voltage	-1025	-870	mV	0°C to +125°C	$V_{IN} = V_{IH(Max)}$ or $V_{IL(Min)}$	Loading with 50Ω to -2.0V	(Notes 3, 4, 5)
		-1085	-870	mV	-55°C			
V_{OL}	Output LOW Voltage	-1830	-1620	mV	0°C to +125°C	$V_{IN} = V_{IH(Min)}$ or $V_{IL(Max)}$	Loading with 50Ω to -2.0V	(Notes 3, 4, 5)
		-1830	-1555	mV	-55°C			
V_{OHC}	Output HIGH Voltage	-1035		mV	0°C to +125°C	$V_{IN} = V_{IH(Min)}$ or $V_{IL(Max)}$	Loading with 50Ω to -2.0V	(Notes 3, 4, 5)
		-1085		mV	-55°C			
V_{OLC}	Output LOW Voltage		-1610	mV	0°C to +125°C	$V_{IN} = V_{IH(Min)}$ or $V_{IL(Max)}$	Loading with 50Ω to -2.0V	(Notes 3, 4, 5)
			-1555	mV	-55°C			
V_{IH}	Input HIGH Voltage	-1165	-870	mV	-55°C to +125°C	Guaranteed HIGH Signal for All Inputs		(Notes 3, 4, 5, 6)
V_{IL}	Input LOW Voltage	-1830	-1475	mV	-55°C to +125°C	Guaranteed LOW Signal for All Inputs		(Notes 3, 4, 5, 6)
I_{IL}	Input LOW Current	0.50		μA	-55°C to +125°C	$V_{EE} = -4.2V$ $V_{IN} = V_{IL(Min)}$		(Notes 3, 4, 5)
I_{IH}	Input HIGH Current		350	μA	0°C to +125°C	$V_{EE} = -5.7V$ $V_{IN} = V_{IH(Max)}$		(Notes 3, 4, 5)
		Data Enable	240	μA				
		Data Enable	500	μA	-55°C			
		Enable	340	μA				
I_{EE}	Power Supply Current	-65	-20	mA	-55°C to +125°C	Inputs Open		(Notes 3, 4, 5)

Note 3: F100K 300 Series cold temperature testing is performed by temperature soaking (to guarantee junction temperature equals -55°C), then testing immediately without allowing for the junction temperature to stabilize due to heat dissipation after power-up. This provides "cold start" specs which can be considered a worst case condition at cold temperatures.

Note 4: Screen tested 100% on each device at -55°C, +25°C, and +125°C, Subgroups 1, 2, 3, 7, and 8.

Note 5: Sample tested (Method 5005, Table I) on each manufactured lot at -55°C, +25°C, and +125°C, Subgroups A1, 2, 3, 7, and 8.

Note 6: Guaranteed by applying specified input condition and testing V_{OH}/V_{OL} .

Military Version AC Electrical Characteristics

$V_{EE} = -4.2V$ to $-5.7V$, $V_{CC} = V_{CCA} = GND$

Symbol	Parameter	$T_C = -55^\circ C$		$T_C = +25^\circ C$		$T_C = +125^\circ C$		Units	Conditions	Notes
		Min	Max	Min	Max	Min	Max			
t_{PLH} t_{PHL}	Propagation Delay Data to Output	0.30	2.00	0.30	1.80	0.30	2.30	ns	Figures 1, 2	(Notes 7, 8, 10, 11)
t_{PLH} t_{PHL}	Propagation Delay Enable to Output	0.50	2.40	0.60	2.30	0.60	2.70	ns		
t_{TLH} t_{THL}	Transition Time 20% to 80%, 80% to 20%	0.30	2.00	0.30	1.90	0.30	2.00	ns		(Note 10)

Note 7: F100K 300 Series cold temperature testing is performed by temperature soaking (to guarantee junction temperature equals $-55^\circ C$), then testing immediately after power-up. This provides "cold start" specs which can be considered a worst case condition at cold temperatures.

Note 8: Screen tested 100% on each device at $+25^\circ C$, Subgroup A9.

Note 9: Sample tested (Method 5005, Table I) on each manufactured lot at $+25^\circ C$, Subgroup A9, and at $+125^\circ C$ and $-55^\circ C$ temperatures, Subgroups A10 and A11.

Note 10: Not tested at $+25^\circ C$, $+125^\circ C$, and $-55^\circ C$ temperature (design characterization data).

Note 11: The propagation delay specified is for single output switching. Delays may vary up to 150 ps with multiple outputs switching.

Test Circuitry

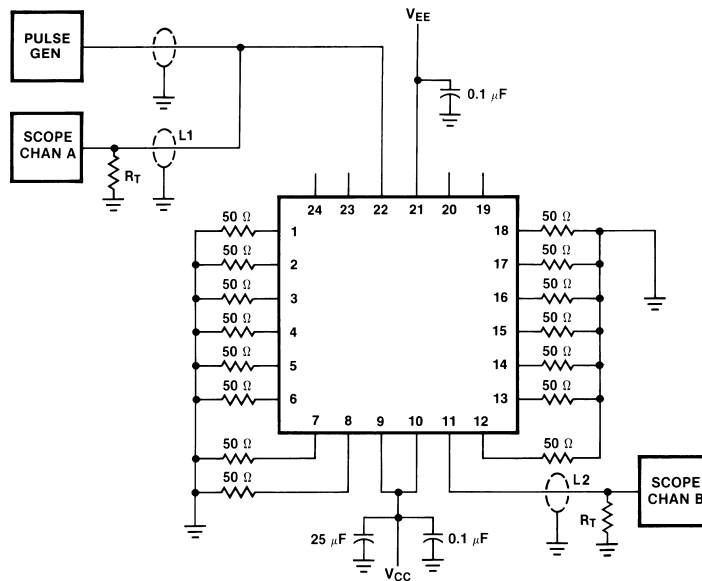

DS100297-5

Notes:

V_{CC} , $V_{CCA} = +2V$, $V_{EE} = -2.5V$.

L1 and L2 = equal length 50Ω impedance lines.

$R_T = 50\Omega$ terminator internal to scope.

Decoupling $0.1\ \mu F$ from GND to V_{CC} and V_{EE} .

All unused outputs are loaded with 50Ω to GND.

C_L = Fixture and stray capacitance $\leq 3\ pF$.

Pin numbers shown are for flatpak; for DIP see logic symbol.

FIGURE 1. AC Test Circuit

Switching Waveforms

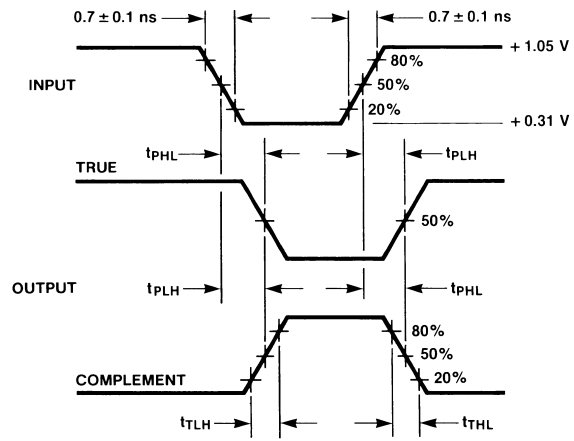

DS100297-6

FIGURE 2. Propagation Delay and Transition Times

Book
Extract
End

Physical Dimensions inches (millimeters) unless otherwise noted

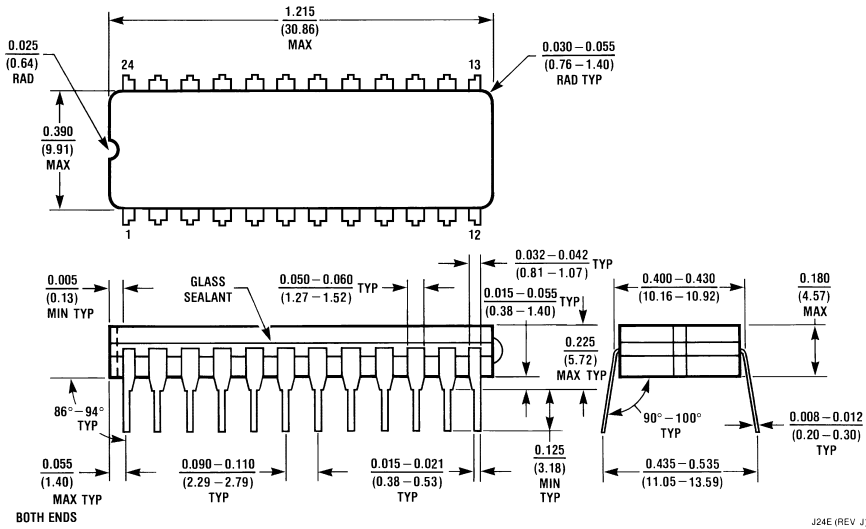

24-Pin Ceramic Dual-In-Line Package (D)
NS Package Number J24E

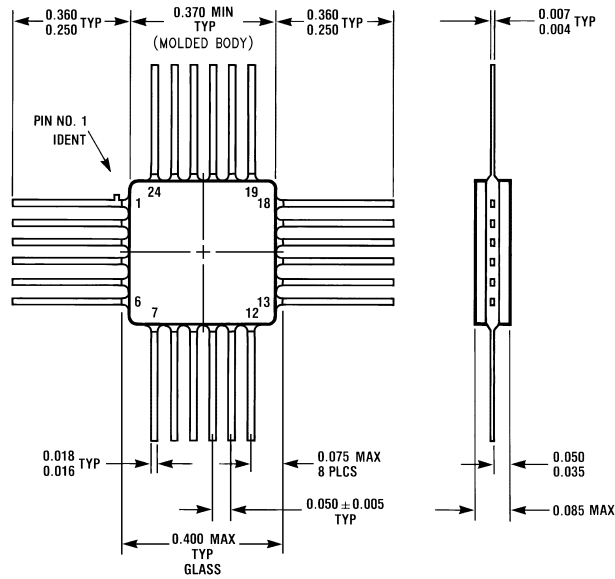

24-Pin Quad Cerpak (F)
NS Package Number W24B

LIFE SUPPORT POLICY

NATIONAL'S PRODUCTS ARE NOT AUTHORIZED FOR USE AS CRITICAL COMPONENTS IN LIFE SUPPORT DEVICES OR SYSTEMS WITHOUT THE EXPRESS WRITTEN APPROVAL OF THE PRESIDENT OF NATIONAL SEMICONDUCTOR CORPORATION. As used herein:

1. Life support devices or systems are devices or systems which, (a) are intended for surgical implant into the body, or (b) support or sustain life, and whose failure to perform when properly used in accordance with instructions for use provided in the labeling, can be reasonably expected to result in a significant injury to the user.
2. A critical component in any component of a life support device or system whose failure to perform can be reasonably expected to cause the failure of the life support device or system, or to affect its safety or effectiveness.



National Semiconductor Corporation
Americas
Tel: 1-800-272-9959
Fax: 1-800-737-7018
Email: support@nsc.com

www.national.com

National Semiconductor Europe
Fax: +49 (0) 1 80-530 85 86
Email: europe.support@nsc.com
Deutsch Tel: +49 (0) 1 80-530 85 85
English Tel: +49 (0) 1 80-532 78 32
Français Tel: +49 (0) 1 80-532 93 58
Italiano Tel: +49 (0) 1 80-534 16 80

National Semiconductor Asia Pacific Customer Response Group
Tel: 65-2544466
Fax: 65-2504466
Email: sea.support@nsc.com

National Semiconductor Japan Ltd.
Tel: 81-3-5620-6175
Fax: 81-3-5620-6179

National does not assume any responsibility for use of any circuitry described, no circuit patent licenses are implied and National reserves the right at any time without notice to change said circuitry and specifications.