

Transistors

2N5400

AMPLIFIER TRANSISTOR

- Collector-Base Voltage: $V_{CE0} = 120V$
- Collector Dissipation: $P_c (\text{max}) = 625mW$

ABSOLUTE MAXIMUM RATINGS ($T_a = 25^\circ C$)

Characteristic	Symbol	Rating	Unit
Collector-Base Voltage	V_{CBO}	-130	V
Collector-Emitter Voltage	V_{CEO}	-120	V
Emitter-Base Voltage	V_{EBO}	-5	V
Collector Current	I_C	-600	mA
Collector Dissipation	P_C	625	mW
Junction Temperature	T_j	150	$^\circ C$
Storage Temperature	T_{stg}	-55 ~ 150	$^\circ C$

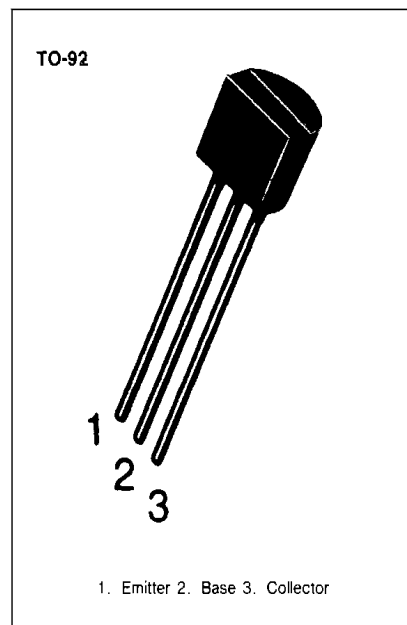

ELECTRICAL CHARACTERISTICS ($T_a = 25^\circ C$)

Characteristic	Symbol	Test Condition	Min	Typ	Max	Unit
Collector-Base Breakdown Voltage	BV_{CBO}	$I_C = -100\mu A, I_E = 0$	-130			V
Collector-Emitter Breakdown Voltage	BV_{CEO}	$I_C = -1mA, I_B = 0$	-120			V
Emitter-Base Breakdown Voltage	BV_{EBO}	$I_E = -10\mu A, I_C = 0$	-5			V
Collector Cut-off Current	I_{CBO}	$V_{CB} = -100V, I_E = 0$			-100	nA
Emitter Cut-off Current	I_{EBO}	$V_{EB} = -3V, I_C = 0$			-50	nA
*DC Current Gain	h_{FE}	$I_C = -1mA, V_{CE} = -5V$	30			
		$I_C = -10mA, V_{CE} = -5V$	40		180	
		$I_C = -50mA, V_{CE} = -5V$	40			
*Collector-Emitter Saturation Voltage	$V_{CE(sat)}$	$I_C = -10mA, I_B = -1mA$			-0.2	V
		$I_C = -50mA, I_B = -5mA$			-0.5	V
*Base-Emitter Saturation Voltage	$V_{BE(sat)}$	$I_C = -10mA, I_B = -1mA$			-1	V
		$I_C = -50mA, I_B = -5mA$			-1	V
Current Gain Bandwidth Product	f_T	$I_C = -10mA, V_{CE} = -10V$ $f = 100MHz$	100		400	MHz
Output Capacitance	C_{ob}	$V_{CB} = -10V, I_E = 0$ $f = 1MHz$			6	pF
Noise Figure	NF	$I_C = -250\mu A, V_{CE} = -5V$ $R_S = 1K\Omega$ $f = 10Hz \text{ to } 15.7KHz$			8	dB

* Pulse Test: Pulse Width = 300 μs , Duty Cycle = 2%

