

Transistors

2N6428A

AMPLIFIER TRANSISTOR

- Collector-Emitter Voltage: $V_{CE0} = 50V$
- Collector Dissipation: $P_c (\text{max}) = 625mW$

ABSOLUTE MAXIMUM RATINGS ($T_a = 25^\circ C$)

Characteristic	Symbol	Rating	Unit
Collector-Base Voltage	V_{CBO}	60	V
Collector-Emitter Voltage	V_{CEO}	50	V
Emitter-Base Voltage	V_{EBO}	6	V
Collector Current	I_c	200	mA
Collector Dissipation	P_c	625	mW
Junction Temperature	T_j	150	$^\circ C$
Storage Temperature	T_{stg}	-55 ~ 150	$^\circ C$

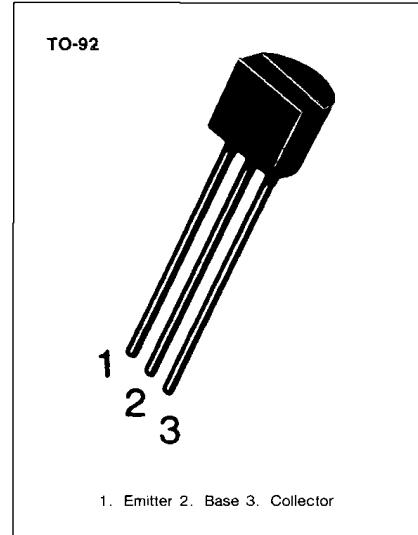

ELECTRICAL CHARACTERISTICS ($T_a = 25^\circ C$)

Characteristic	Symbol	Test Conditions	Min	Typ	Max	Unit
Collector-Base Breakdown Voltage	BV_{CBO}	$I_c = 100\mu A, I_E = 0$	60			V
Collector-Emitter Breakdown Voltage	BV_{CEO}	$I_c = 1mA, I_B = 0$	50			V
Collector Cut-off Current	I_{CBO}	$V_{CB} = 30V, I_E = 0$			10	nA
Collector Cut-off Current	I_{CEO}	$V_{CE} = 30V, I_B = 0$			25	nA
Base Cut-off Current	I_{EBO}	$V_{BE} = 5V, I_C = 0$			10	nA
DC Current Gain	h_{FE}	$V_{CE} = 5V, I_c = 10\mu A$	250			
		$V_{CE} = 5V, I_c = 100\mu A$	250		650	
		$V_{CE} = 5V, I_c = 1mA$	250			
		$V_{CE} = 5V, I_c = 10mA$	250			
Collector-Emitter Saturation Voltage	$V_{CE} (\text{sat})$	$I_c = 10mA, I_B = 0.5mA$			0.2	V
		$I_c = 100mA, I_B = 5mA$			0.6	V
Base-Emitter On Voltage	$V_{BE} (\text{on})$	$I_c = 1mA, V_{CE} = 5V$	0.56		0.66	V
Output Capacitance	C_{OB}	$V_{CB} = 10V, I_E = 0$			3	pF
Current Gain Bandwidth Product	f_T	$V_{CE} = 5V, I_c = 1mA$ $f = 1MHz$	100		700	MHz
Noise Figure/Noise Voltage Level	N_F/N_v	$V_{CE} = 5V, I_c = 100\mu A$ (1) $R_S = 10K\Omega, B_w = 1Hz$ $f = 100Hz$			2/16.2	dB/nV
		(2) $R_S = 50K\Omega, B_w = 15.7KHz$ $f = 10Hz - 10KHz$			4/4.6	dB/nV
		(3) $R_S = 500\Omega, B_w = 1Hz$ $f = 10Hz$			3/4.1	dB/nV