

Transistors

2N6519

HIGH VOLTAGE TRANSISTOR

ABSOLUTE MAXIMUM RATINGS ($T_a=25^\circ\text{C}$)

Characteristic	Symbol	Rating	Unit
Collector-Base Voltage	V_{CBO}	-300	V
Collector-Emitter Voltage	V_{CEO}	-300	V
Emitter-Base Voltage	V_{EBO}	-5	V
Collector Current	I_C	-500	mA
Base Current	I_B	-250	mA
Collector Dissipation	P_C	0.625	W
Derate above 25°C		5	mW/ $^\circ\text{C}$
Junction Temperature	T_j	150	$^\circ\text{C}$
Storage Temperature	T_{stg}	-55~150	$^\circ\text{C}$

• Refer to 2N6520 for graphs

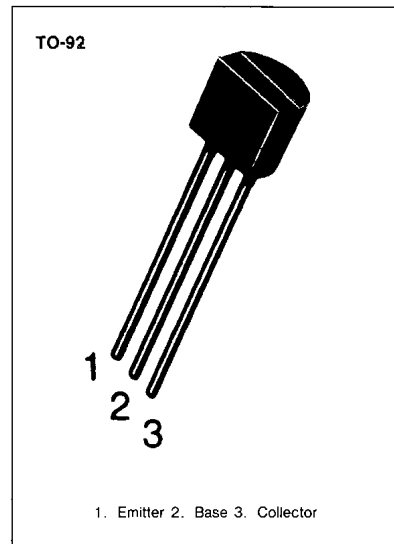

ELECTRICAL CHARACTERISTICS ($T_a=25^\circ\text{C}$)

Characteristic	Symbol	Test Condition	Min	Max	Unit
Collector Base Breakdown Voltage	BV_{CBO}	$I_C=-100\mu\text{A}, I_E=0$	-300		V
*Collector Emitter Breakdown Voltage	BV_{CEO}	$I_C=-1\text{mA}, I_B=0$	-300		V
Emitter Base Breakdown Voltage	BV_{EBO}	$I_E=-10\mu\text{A}, I_C=0$	-5		V
Collector Cutoff Current	I_{CBO}	$V_{CB}=-200\text{V}, I_E=0$		-50	nA
Emitter Cutoff Current	I_{EBO}	$V_{EB}=-4\text{V}, I_C=0$		-50	nA
*DC Current Gain	h_{FE}	$V_{CE}=-10\text{V}, I_C=-1\text{mA}$	30		
		$V_{CE}=-10\text{V}, I_C=-10\text{mA}$	45		
		$V_{CE}=-10\text{V}, I_C=-30\text{mA}$	45	270	
		$V_{CE}=-10\text{V}, I_C=-50\text{mA}$	40	200	
		$V_{CE}=-10\text{V}, I_C=-100\text{mA}$	20		
Collector-Emitter Saturation Voltage	$V_{CE}(\text{sat})$	$I_C=-10\text{mA}, I_B=-1\text{mA}$		-0.30	V
		$I_C=-20\text{mA}, I_B=-2\text{mA}$		-0.35	V
		$I_C=-30\text{mA}, I_B=-3\text{mA}$		-0.50	V
		$I_C=-50\text{mA}, I_B=-5\text{mA}$		-1	V
Base-Emitter Saturation Voltage	$V_{BE}(\text{sat})$	$I_C=-10\text{mA}, I_B=-1\text{mA}$		-0.75	V
		$I_C=-20\text{mA}, I_B=-2\text{mA}$		-0.85	V
		$I_C=-30\text{mA}, I_B=-3\text{mA}$		-0.90	V
Base Emitter On Voltage	$V_{BE}(\text{on})$	$V_{CE}=-10\text{V}, I_C=-100\text{mA}$		-2	V
*Current Gain Bandwidth Product	f_T	$V_{CE}=-20\text{V}, I_C=-10\text{mA}, f=20\text{MHz}$	40	200	MHz
Collector Base Capacitance	C_{cb}	$V_{CB}=-20\text{V}, I_E=0, f=1\text{MHz}$		6	pF
Emitter Base Capacitance	C_{eb}	$V_{EB}=-0.5\text{V}, I_C=0, f=1\text{MHz}$		100	pF
Turn On Time	t_{on}	$V_{BE}(\text{off})=-2\text{V}, V_{CC}=-100\text{V}$ $I_C=-50\text{mA}, I_B1=-10\text{mA}$		200	ns
Turn Off Time	t_{off}	$V_{CC}=-100\text{V}, I_C=-50\text{mA}$ $I_B1=I_B2=-10\text{mA}$		3.5	ns

* Pulse Test: $PW=300\mu\text{s}$, Duty Cycle=2%

